



Doc. No.	NDP 477M-04
----------	-------------

MAINTENANCE MANUAL
YAMADA AIR-OPERATED DOUBLE DIAPHRAGM PUMP

NDP-50-PP

WARNING



- For your own safety, be sure to read these procedures carefully before performing maintenance on this product. After reading this document, be sure to keep it handy for future reference.

This maintenance manual covers what you should know about maintenance of the Yamada NDP-50-PP series Diaphragm Pumps.

This edition is based on the standards for the March 2022 production run. Remember, the specifications are always subject to change; therefore, some of the information in this edition may not apply to new specifications.

- **Warnings and Cautions**

For safe use of this product, be sure to note the following: In this document, warnings and cautions are indicated by symbols. These symbols are for those who will operate this product and for those who will be nearby, for safe operation and for prevention of personal injury and property damage. The following warning and caution symbols have the meanings described below. Be sure to remember their meanings.



WARNING : If you ignore the warning described and operate the product in an improper manner, there is danger of serious bodily injury or death.



CAUTION : If you ignore the caution described and operate the product in an improper manner, there is danger of personal injury or property damage.

Furthermore, to indicate the type of danger and damage, the following symbols are also used along with those mentioned above:



This symbol indicates a DON'T, and will be accompanied by an explanation on something you must not do.



This symbol indicates a DO, and will be accompanied by instructions on something you must do in a certain situation.

WARNING



- Before starting maintenance work, cut off the feed air and clean the pump. If air pressure or residue remain in the pump, there is danger of explosion, or possible poisoning resulting in serious injury or death if chemicals adhere to the skin or are accidentally swallowed. (For details on cleaning the pump, refer to Chapter 6 of the Operation Manual.)



- When replacing parts, be sure to use the recommended genuine parts or Equivalents. Use of other parts may cause a malfunction of the product. (Refer to Parts list the separate sheets.)

CAUTION



- When it is instructed that special tools must be used, be sure to use the specified tools. Otherwise, the pump may be damaged.



- Refer to "10.1 Specifications" in the Operation Manual. Also, remember that the pump is heavy, and extreme care must be taken when lifting it.



- Stainless steel bolts and nuts are used to fix the casing. Use anti-seize lubricant when screwing these.

Table of Contents

-Warnings and Cautions

-Table of Contents

1. Principles of operation	1
2. Maintenance and Tools	
2.1 Maintenance.....	1
2.2 General tools.....	1
2.3 Special tools.....	1
2.4 Misc.	1
3. Ordering Replacement parts	1
4. Balls and Valve seats	
4.1 Removal.....	2
4.2 Inspection.....	3
4.3 Installation.....	3
5. Diaphragm and Center rod	
5.1 Removal.....	4
5.2 Inspection.....	5
5.3 Installation.....	6
6. Throat bearing and Pilot valve Assembly	
6.1 Removal.....	11
6.2 Inspection.....	11
6.3 Installation.....	11
7. C Spool Valve Assembly	
7.1 Removal.....	12
7.2 Inspection.....	13
7.3 Installation.....	13
8. Retightening of Tie rods	14

1. Principles of operation

There are two diaphragms fixed to the center rod, one at each end. When compressed air is supplied to air chamber b (right side, see Fig.1.1), the center rod moves to the right, the material in material chamber B is pushed out, and at the same time material is sucked into material chamber A.

When the center rod is moved full-stroke to the right, the air switch valve is switched, compressed air is sent to air chamber a (left side, see Fig.1.2), and the center rod moves to the left. The material in material chamber A is pushed out, and at the same time material is sucked into material chamber B.

Through repetition of this operation, material is repeatedly taken in and discharged out.

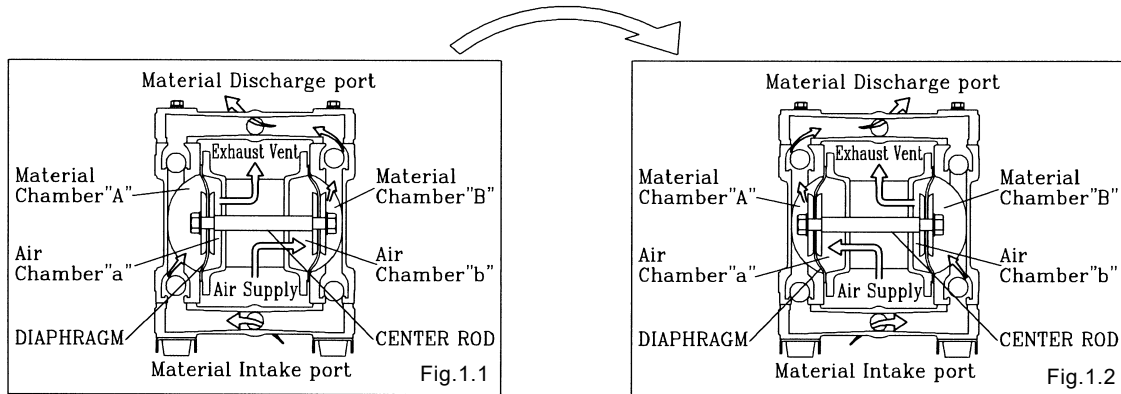

2. Maintenance and Tools

2.1 Maintenance

Since APDD (air powered double diaphragm pumps) can be used in many different applications varying in pressure, temperature, viscosity corrosiveness, and other properties, it is best to do a periodic inspection of the pump. Recording data on each installed pump during inspections will also serve as a record for any future maintenance. Typical maintenance involves inspection of the air valve, diaphragms, balls, valve seats and O-rings. BOTH diaphragms should be replaced if they show any sign of wear, abrading, or cracking. Refer to this manual for acceptable measurable working tolerances on other wearing components.

2.2 General tools

- Socket wrenches 13mm, 17mm, 19mm
- Hexagonal box wrenches 6mm
- Small crowbars 2 (B_C, B_N, B_E, B_V)
- Open-end wrenches 19mm, 24mm
- Plastic hammer • Phillips head screw driver • Adjustable angle wrenches • Needle Nose Pliers

2.3 Special tools

- PP wrench (sold separately)

Purpose: Removing the center disk

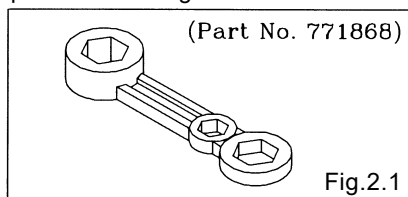

Fig.2.1

- Sleeve remover (sold separately)

Purpose: For removing sleeve

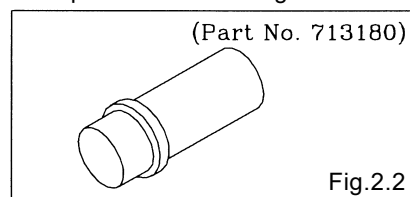

Fig.2.2

2.4 Misc.

- Assembly oil Turbine oil none addition class 1 (equivalent ISO VG32 grade)
- Nuts M16 X 1.5
- Thread locker
- Grease Urea grease grade (NLGI) No. 2
- Air regulator The one which is adjustable in 14 PSI increments

3. Ordering Replacement parts

For accurate and speedy shipment of parts, be sure to order the right parts for your model to distributor. Indicate the part numbers, descriptions, and quantities.

4. Balls and Valve seats

4.1 Removal

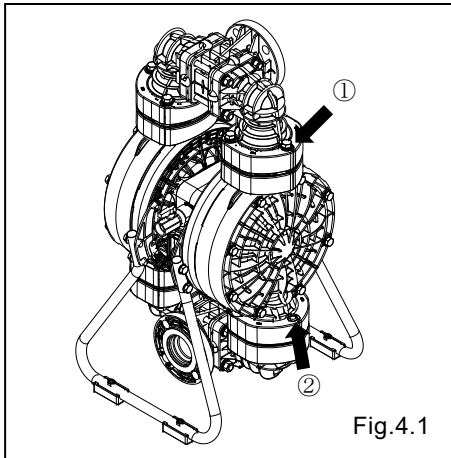

- Remove the 6 retainer bolts “1” from the out manifold, and remove the protector and out manifold.
- Remove the Silencer. [Fig.4.1]

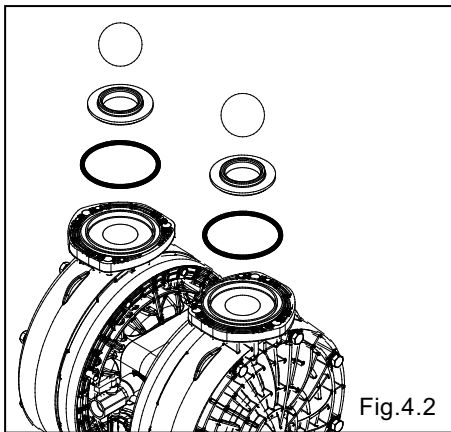

- Remove the ball, valve seat and O ring. [Fig.4.2]

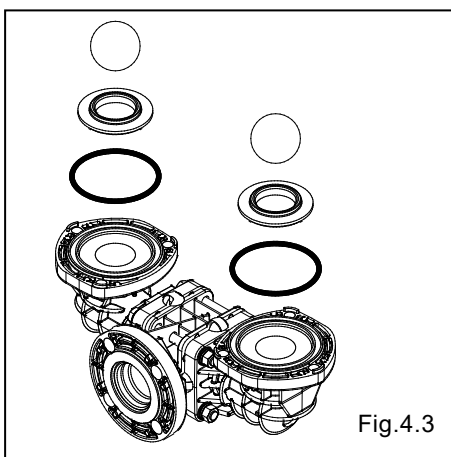

- Remove the 6 retainer bolts “2” from the in manifold, and remove the protector and in manifold. [Fig.4.1]
- Remove the ball, valve seat and O ring. [Fig.4.3]

4.2 Inspection

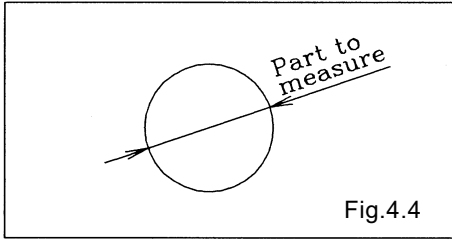

- Ball [Fig.4.4]
Measure the outside diameter, and if it is outside the usable range, replace the ball.

Usable range of ball
 $S\phi 2.232 - S\phi 2.555$ in.
 $\{S\phi 56.7 - S\phi 64.9$ mm}

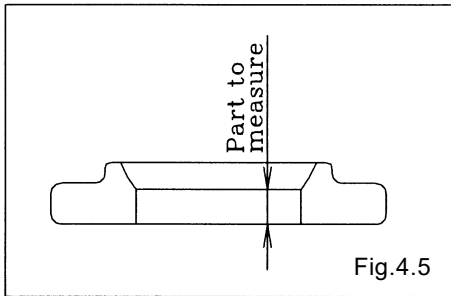

- Valve seat [Fig.4.5]
Measure the dimension shown at left, and if it is outside the usable range, replace the seat.

Usable range of valve seat

B_C, B_N, B_E B_V, B_H, B_S	B_T
0.197 - 0.492 in. {5.0 - 12.5 mm}	0.067 - 0.161 in. {1.7 - 4.1 mm}

- O ring (other than PTFE)
If O ring is worn out or cracked, replace it.

4.3 Installation

For installation, see [Exploded View] on the separate sheet and install in the reverse order of disassembly.

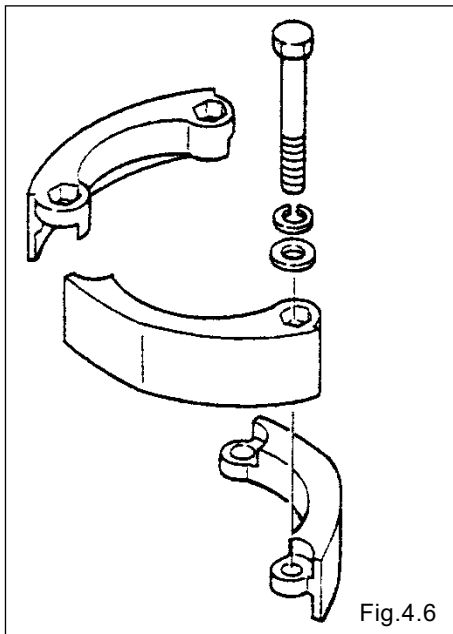

Tightening torque for manifold retainer bolts

BP_, BV_	18 ft-lbf {25 N-m}
----------	--------------------

<NOTE>

- Make sure there is no dust on the seal surface and the seal is not damaged.
- Replace the PTFE O ring regardless of its condition.
- Match the convex and concave parts of the protector. [Fig.4.6]

5. Diaphragm and Center rod

5.1 Removal

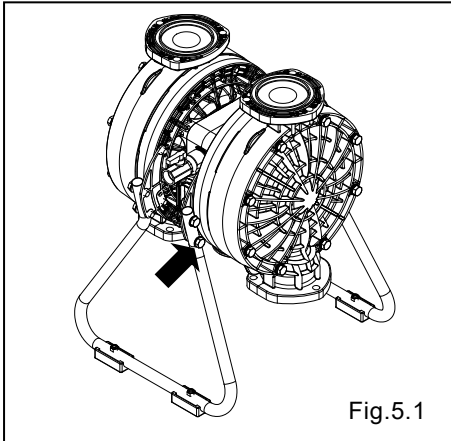

- Remove the ball etc. (see “4.1 Removal”).
- Remove the 8 retainer bolts from the stand body, and remove the stand body. [Fig.5.1]

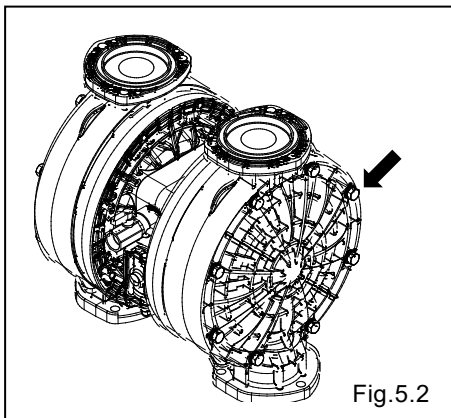

- Unscrew 16 bolts (include 8 bolts mentioned above) from the out chamber and remove the out chamber. [Fig.5.2]

■BP_, BV_ types (excluding B□W)

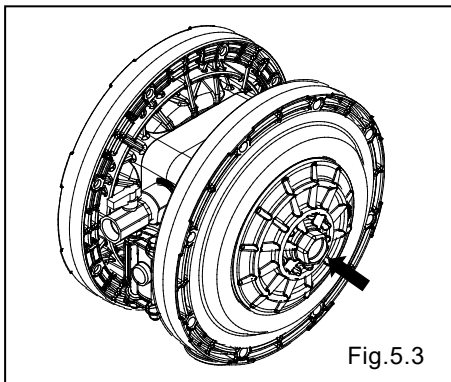

- Remove the center disk from one side using the PP wrench (special tool: Part No. 771868). [Fig.5.3]
- After the center disk (outside) has been removed, remove the diaphragm and the center disk (inside). Remove the center disk and center rod from the opposite side of the main body.

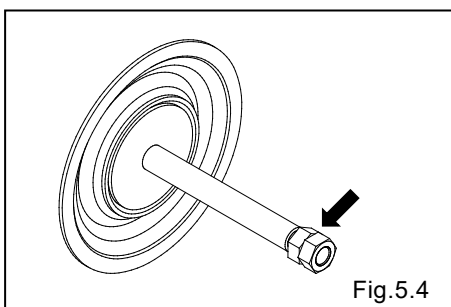

- Fix a double nut to one end of the center rod and take the diaphragm and center disk off the opposite end. [Fig.5.4] Be careful not to scratch or score the center rod.

■ B_W type

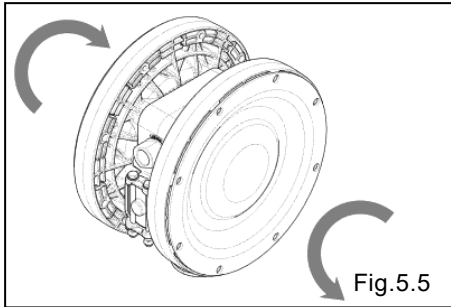

- Remove the diaphragms from both sides [Fig. 5.5].
- When one of the diaphragms is removed, take out the center disk and cushion. Then remove the other diaphragm, the center disk, the cushion and the center rod from the main body.

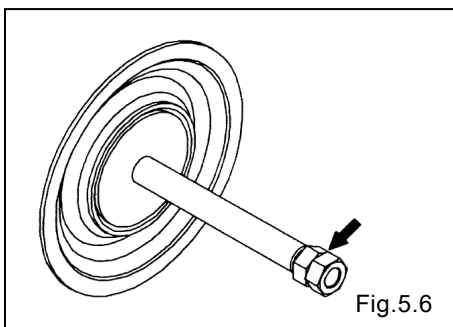

- Remove the other diaphragm by using a double nut, then take the diaphragm, the center disk and cushion out of the center rod [Fig. 5.6].

5.2 Inspection

- Diaphragm
If the diaphragm is worn out or damaged, replace it.
Never replace just one diaphragm.

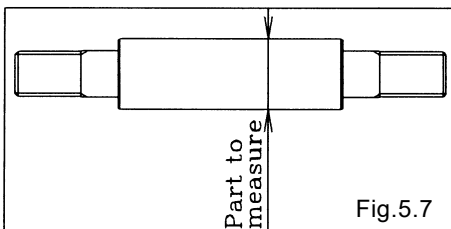

- Center rod [Fig. 5.7]
Measure the diameter, and if it is outside the usable range, replace the rod.

Usable range of center rod

$\emptyset 0.9815 - \emptyset 0.9843$ in. { $\emptyset 24.93 - \emptyset 25.00$ mm}

5.3 Installation

■ B_C, B_N, B_E, B_V, B_H, B_S types

For installation, see [Exploded View] on the separate sheet and install in the reverse order of disassembly.

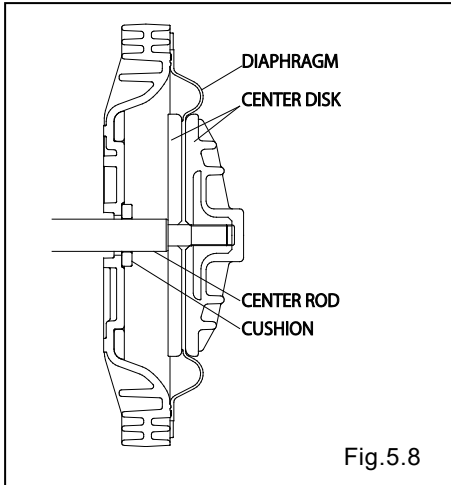

- Apply assembly grease to the center rod, and insert it into the main body.
- Insert the cushion.
- Keep the marking “OUTSIDE” to liquid end for CR, NBR, EPDM, FKM diaphragms. Keep the convex side to the outside for TPEE, TPO diaphragms.
- Apply thread locker to center disk and tighten the center disk by the PP wrench (special tool, part number 771868).

Tightening torque for center rod

36 ft-lbf {50 N-m}

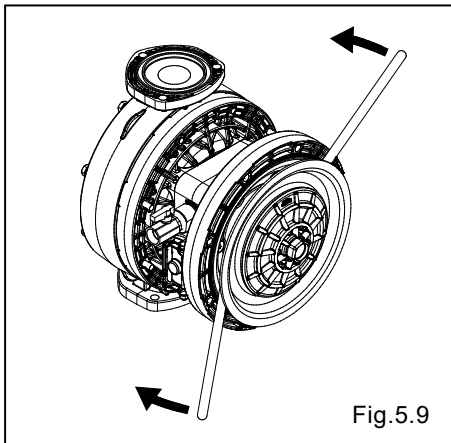

- Draw the center disk to one side (exclude B_H, B_S type cf. Fig. 5.8).
- And install the out chamber. Tighten the bolts temporarily.
- Grip the inside center disk using crowbars and draw it to the opposite side, then turn the diaphragm over. (exclude B_H, B_S type) [Fig. 5.9, 5.10]
- And install the out chamber. Tighten the bolts temporarily.
- After installation of the out chambers on both sides, place the pump on a flat surface and stand the pump upright for further assembly.

Tightening torque for out chamber.

26 ft-lbf {35 N-m}

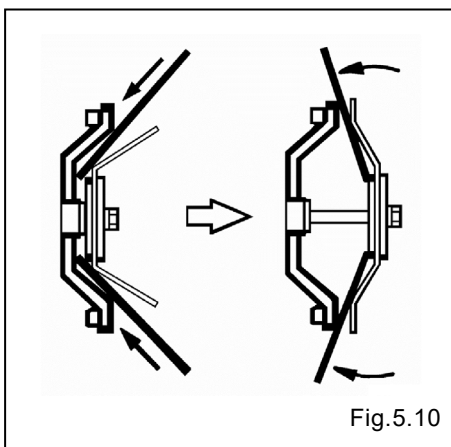

<NOTE>

- Make sure there is no dust on the seal surface in order to prevent seal damaged.
- Be careful not to damage the R portion and serrations of the air chamber using a crowbar, etc.
- Tighten the bolts gradually in a diagonal sequence with even torque. (cf. Fig. 5.11)

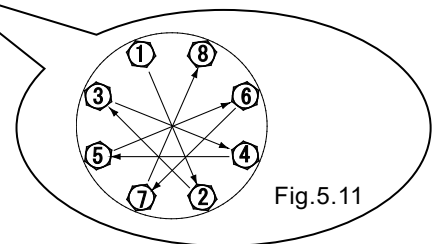

■ B_T type

For installation, see [Exploded View] on the separate sheet and install in the reverse order of disassembly.

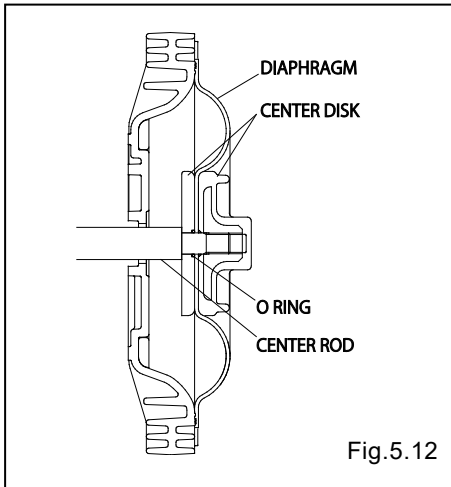

- Apply assembly grease to the center rod, and insert it into the main body.
- Keep the convex side to the outside (cf. Fig. 5.12).
- Put the O rings to both sides of the diaphragm. (cf. Fig. 5.12)
- Apply thread locker to center disk and tighten the center disk by the PP wrench (special tool, part number 771868).

Tightening torque for center rod

36 ft-lbf {50 N-m}

- Tighten the out chamber temporarily at first. After installation of the out chambers on both sides, place the pump on a flat surface and stand the pump upright for further assembly.

Tightening torque for out chamber

26 ft-lbf {35 N-m}

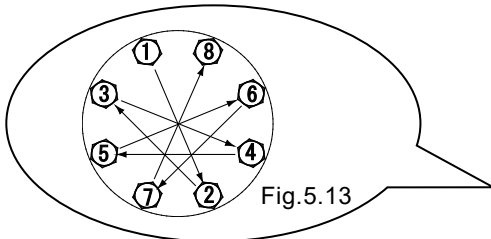

<NOTE>

- Make sure there is no dust on the seal surface in order to prevent seal damaged.
- Replace the PTFE O ring by new one.
- Tighten the bolts gradually in a diagonal sequence with even torque. (cf. Fig. 5.13)

■ B□W type

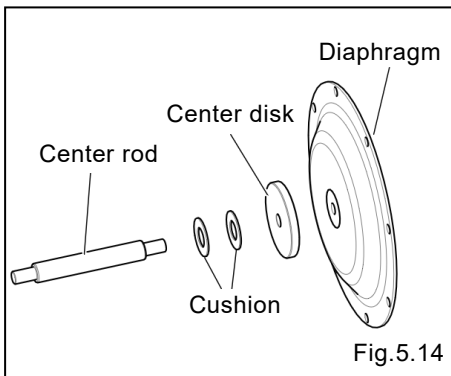

- Install the cushion, the center disk, and then the diaphragm in this order to one side of the center rod. [Fig. 5.14].

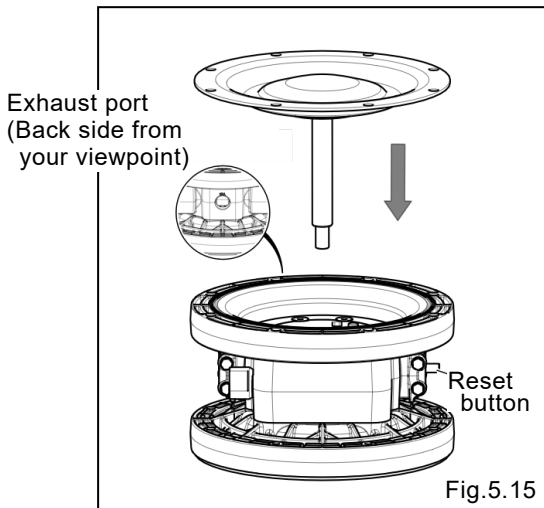

- Place the main body so that the exhaust port will be at the back side and the reset button will face to the right from your viewpoint.
- Apply grease to the center rod and the inside of the throat bearings before inserting the center rod into the main body [Fig. 5.15].

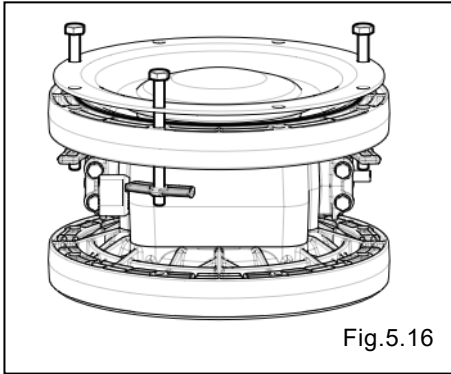

Fig.5.16

- Adjust the positions of the diaphragm holes to the screw holes on the air-chamber. Then put three bolts through three of the diaphragm holes and temporarily tighten the bolts. At this point, there should be even intervals between these three bolts or three holes. (The bolts should be tightened by using the backing plates as Fig.5.16.)

< NOTE >

Those three bolts are to fix the positions of the holes on the air-chamber and the diaphragm. So tentatively tighten those bolts by rotating them by hand three to four times.

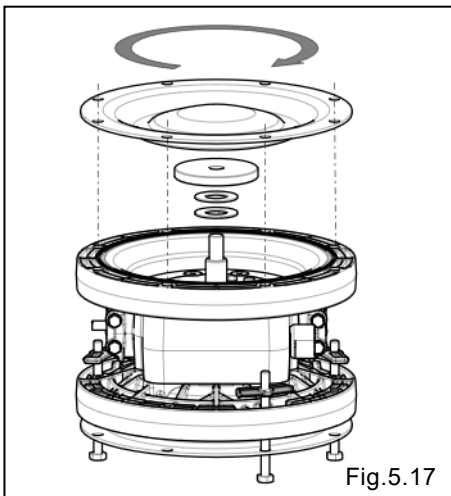

Fig.5.17

- Install the cushion, the center disk, and the diaphragm to the other side of the center rod.
- Rotate the diaphragm clockwise by hand until it's tightened [Fig.5.17].

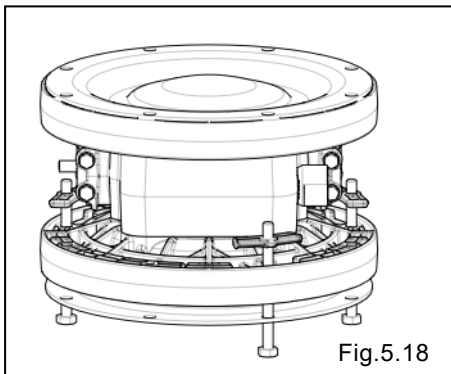

Fig.5.18

- When tightening the diaphragm at Fig. 5.20, the holes on the diaphragm should be at the same positions as the 8 screw holes on the air-chamber. Basically, those hole positions should be adjusted by rotating the diaphragm clockwise. If it is difficult, move the diaphragm counter-clockwise a little bit to adjust them [Fig.5.18]

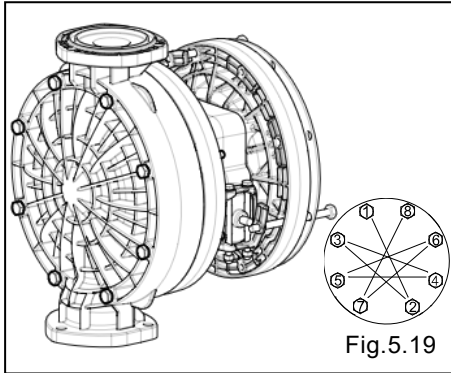

Fig.5.19

- Install the out-chamber to the side where the diaphragm has been put on, as mentioned in the above Fig.5.21. [Fig.5.18].
- Put the bolts through the holes on the air-chamber, checking which kind of backing plates are used. [Fig.5.19 Arrow View]
A: With screws, B: Without screws

Tightening torque for out chamber.

26 ft-lbf {35 N·m}

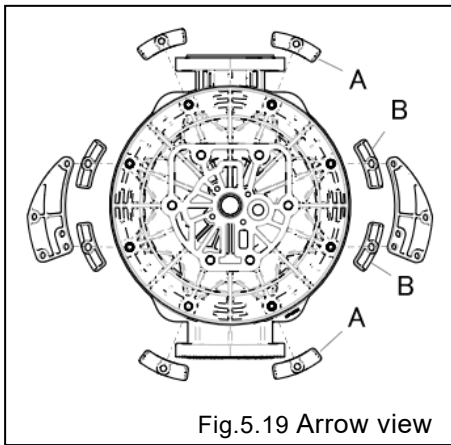

Fig.5.19 Arrow view

<NOTE>

- Fig.5.19 shows the standard positions of the out-chambers and the valve body assembly. But those positions can be freely changed, depending on how and where the pump will be installed.
- Tighten the bolts gradually in a diagonal sequence with even torque.

⚠ CAUTION



▪ Be careful not to get your finger stuck between the diaphragm and the out-chamber.



▪ Connect the air hose after confirming that the air valve and the air regulator are closed. The diaphragms will suddenly move when the air is suddenly supplied, which will cause serious injury.

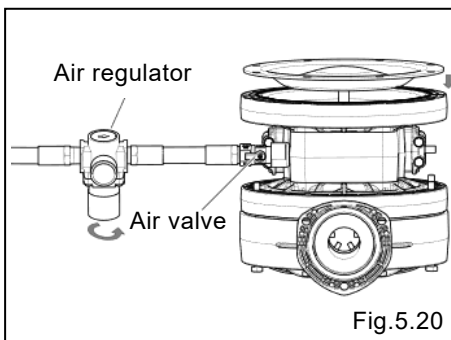
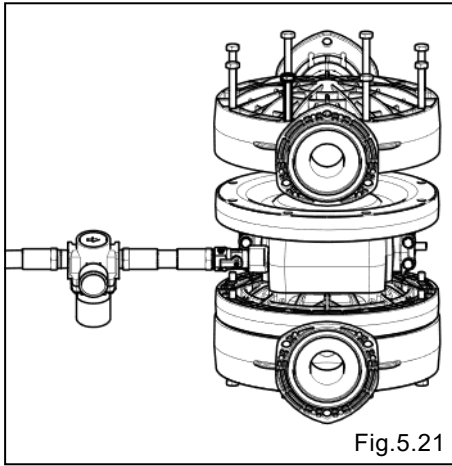
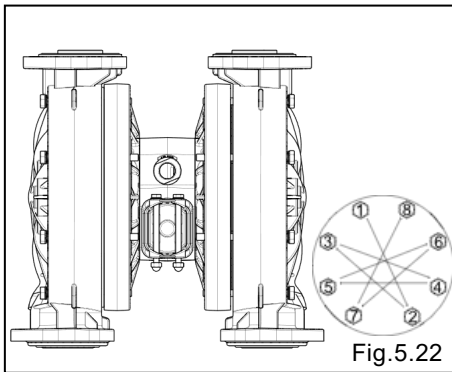

Fig.5.20

- Remove the bolts that were temporarily fastened at Fig.5.16.
- Install the silencer to the exhaust port, and the air valve and regulator to the air supply port.
- Press the reset button, open the valve, and gradually open the air regulator until the air supply pressure becomes a little bit below 14 PSI. Then the diaphragm will slowly go down. (If the diaphragm doesn't move at the pressure 14 PSI, stop the air supply and check if there is nothing wrong with how the pump is assembled.) [Fig.5.20]



- When the diaphragm finally touches the air chamber and there becomes no gap between the diaphragm and the air-chamber, install the other out-chamber with the air being supplied. [Fig.5.21]



- Tighten the bolts by hand. Close the air regulator and air valve. Then remove the silencer.
- Ensure that the out-chambers on both sides are aligned parallel to each other. Adjust them if not.
- Tighten the bolts on the out-chambers (please refer to the previous chapter 'Tightening torque for out-chambers' [Fig.5.22]).

< NOTE >

Tighten the bolts gradually in a diagonal sequence with even torque.

6. Throat bearing and Pilot valve assembly

6.1 Removal

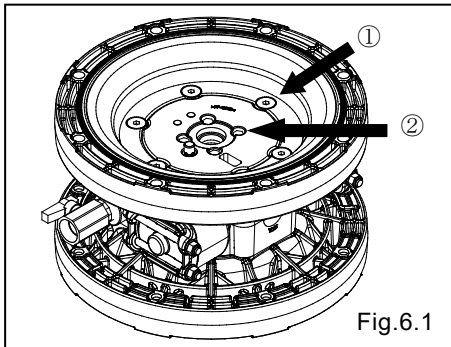

- Remove the diaphragm and center rod (see "5.1 Removal").
- Unscrew 12 bolts (①) and 8 tapping screws (②), and remove the air chamber. [Fig.6.1]

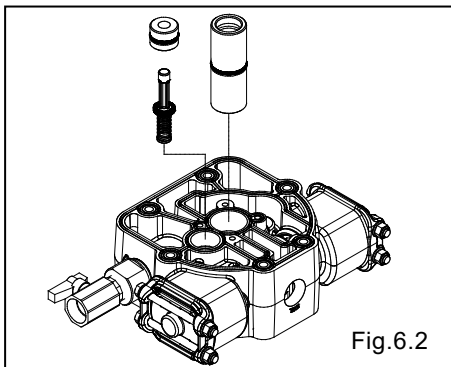

- Pull the pilot valve and valve seat out. [Fig.6.2]
- Pull the throat bearing out. [Fig.6.2]
- *Push these out from the other side if cannot be removed.

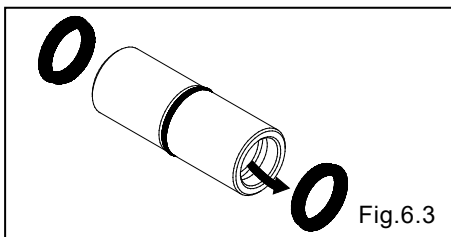

- Remove the packing from the throat bearing. [Fig.6.3]

6.2 Inspection

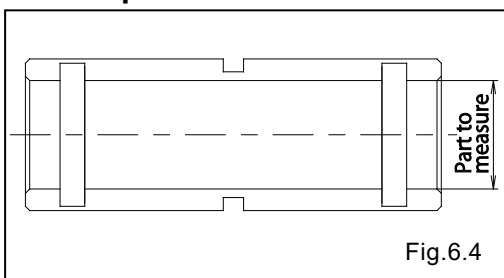

- Throat bearing [Fig.6.4]
Measure the inside diameter, and if it is outside the usable range, replace the throat bearing

Usable range of throat bearing

$\varnothing 0.9859 - \varnothing 0.9894$ in. { $\varnothing 25.04 - \varnothing 25.13$ mm}

- O ring, Packing
If the O ring is worn out or cracked, replace it.
- Pilot valve
If the pilot valve is worn out or cracked, replace it.

6.3 Installation

For installation, see [Exploded View] on the separate sheet and install in the reverse order of disassembly.

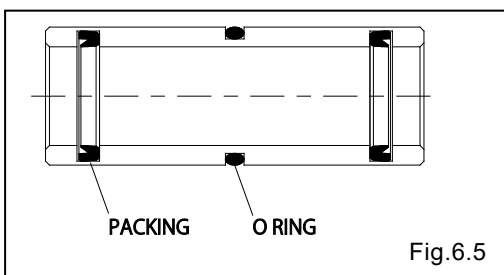

Tightening torque for air chamber retainer bolts

15 ft-lbf {20 N-m}

Tightening torque for tapping screws

4 ft-lbf {5 N-m}

<NOTE>

- Make sure there is no dust on the seal surface and the seal is not damaged.
- Apply grease to packing.

7. C spool valve assembly

7.1 Removal

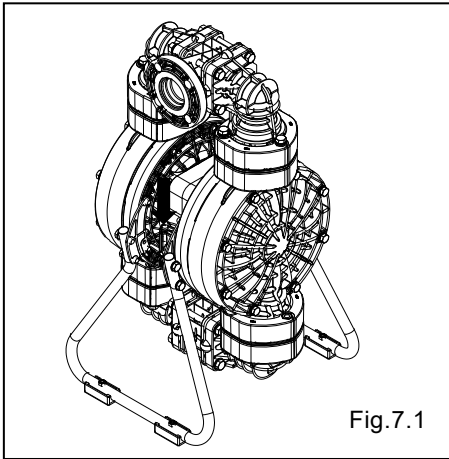

- Remove the 4 cap A and cap B retainer bolts, and remove cap A and cap B. [Fig.7.1]

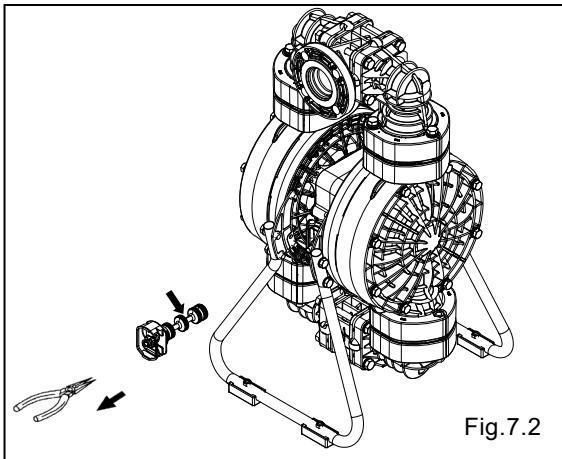

- Draw out the C spool valve assembly, and remove the seal ring from the C spool valve assembly.
- Remove the spring stopper. [Fig.7.2]

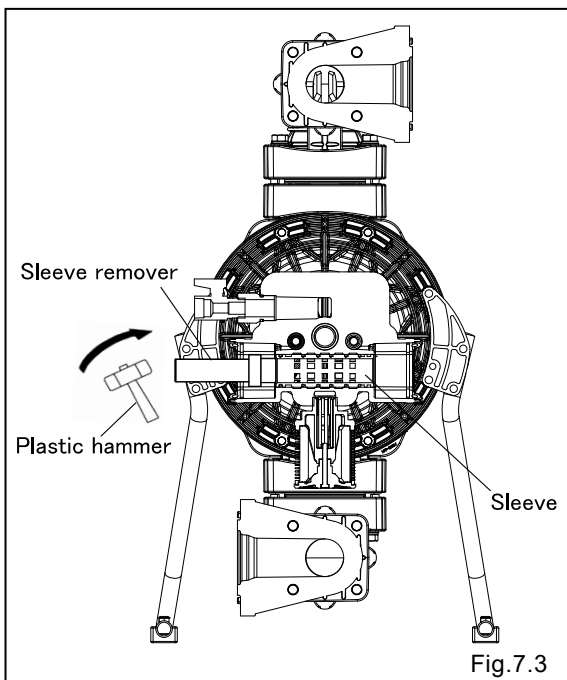

- Remove the sleeve using the sleeve remover (special tool: Part number 713180). [Fig.7.3]

7.2 Inspection

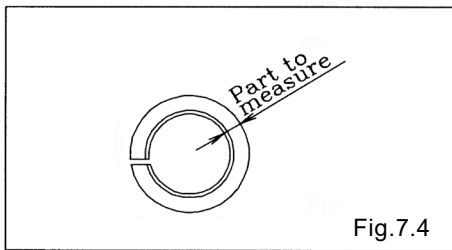

- C Spool Valve Assembly
Seal ring [Fig.7.4]
Measure the inside thick diameter, and if it is outside the usable range, replace the C Spool Valve Assembly.
If the seal ring is worn out or cracked, replace C Spool Valve Assembly.

Usable range of Seal ring

0.1484 - 0.1516 in. {3.77 - 3.85 mm}

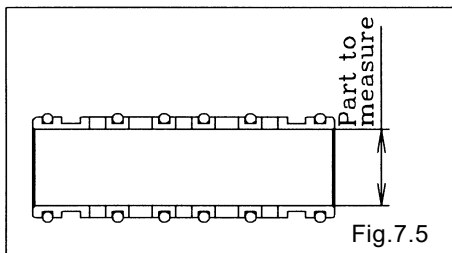

- Sleeve Assembly [Fig.7.5]
Measure the inside diameter, and if it is outside the usable range, replace the c spool valve assembly.

Usable range of sleeve

ø1.305 - ø1.313 in. {ø33.15 - ø33.35 mm}

- O ring
If the O ring is worn out or cracked, replace it.

<NOTE>

- C Spool Valve Assembly must be replaced as a complete set.
Unable to replace individual component.

7.3 Installation

For installation, see [Exploded View] on the separate sheet and install in the reverse order of disassembly.

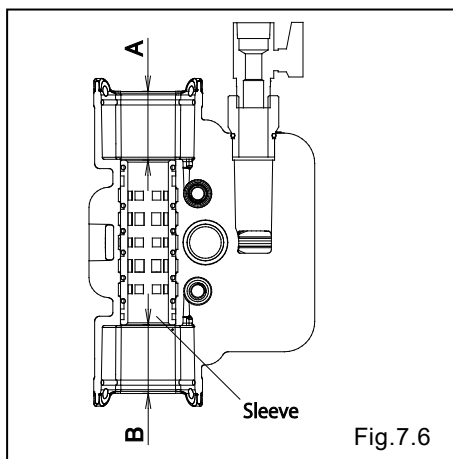

- Install the sleeve using the sleeve remover (special tool: Part No. 713180). At this point, apply assembly oil around the sleeve and O ring.
- Install the sleeve at the center of the valve body. (A = B)

Tightening torque for installation cap A, cap B

4 ft-lbf {5 N-m}

<NOTE>

- Make sure there is no dust on the seal surface and it is not damaged.

8. Retightening of Tie rods

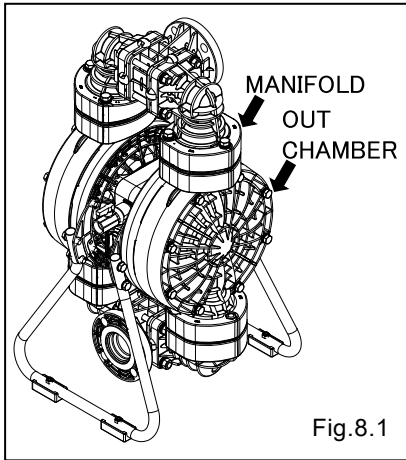

- All bolts should be retorqued:
 - (1) Right before start up.
 - (2) There are any leaks of material on daily inspecting a pump.

Retain bolts for the out chamber	Retain bolts for the manifold
26 ft-lbf {35 N-m}	15 ft-lbf {20 N-m}

<NOTE>

- Retighten the Out chamber and then the manifold in this order. [Fig.8.1]
- Tighten the bolts in the order shown. [Fig.8.2]

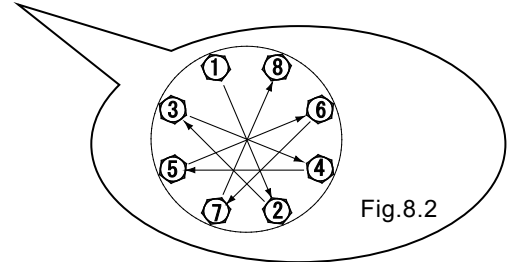

YAMADA AMERICA, INC

955 E. ALGONQUIN RD., ARLINGTON HEIGHTS, IL 60005, USA

PHONE : 1-847-631-9200 or 1-800-990-7867 (Toll Free)

FAX : 1-847-631-9273

E-mail : sales@yamadapump.com

Web : www.yamadapump.com

Manufactured by:

YAMADA CORPORATION

International Department

1-1-3, Minami-Magome, Ota ku, Tokyo, 143-8504, Japan

PHONE : +81-(0)3-3777-0241

FAX : +81-(0)3-3777-0584

E-mail : intl@yamadacorp.co.jp

Web : www.yamadacorp.co.jp

202203.2623 NDP477M